

SILENT PILER

The Multi-functional silent piler adopts full hydraulic drive and full automatic control. It has the advantages of no vibratory. By replacing different models or fixtures, it can be applied to various pile types. The maximum pulling force can reach 150Tons.

 Silent  Stable  Efficient  Safe



FEATURES:

1. No noise, no vibration, small influence during engineering,
2. Small equipment volume, convenient to transfer to new construction field.
3. It can also add the water knife system and rotary digging system according to the different geological conditions.
4. Available for a wide range of piles such as U Type steel sheet pile, Z Type Steel sheet pile, H Beam, Pipe Pile, PHC pile and so on.
5. Precise design, reliable performance.



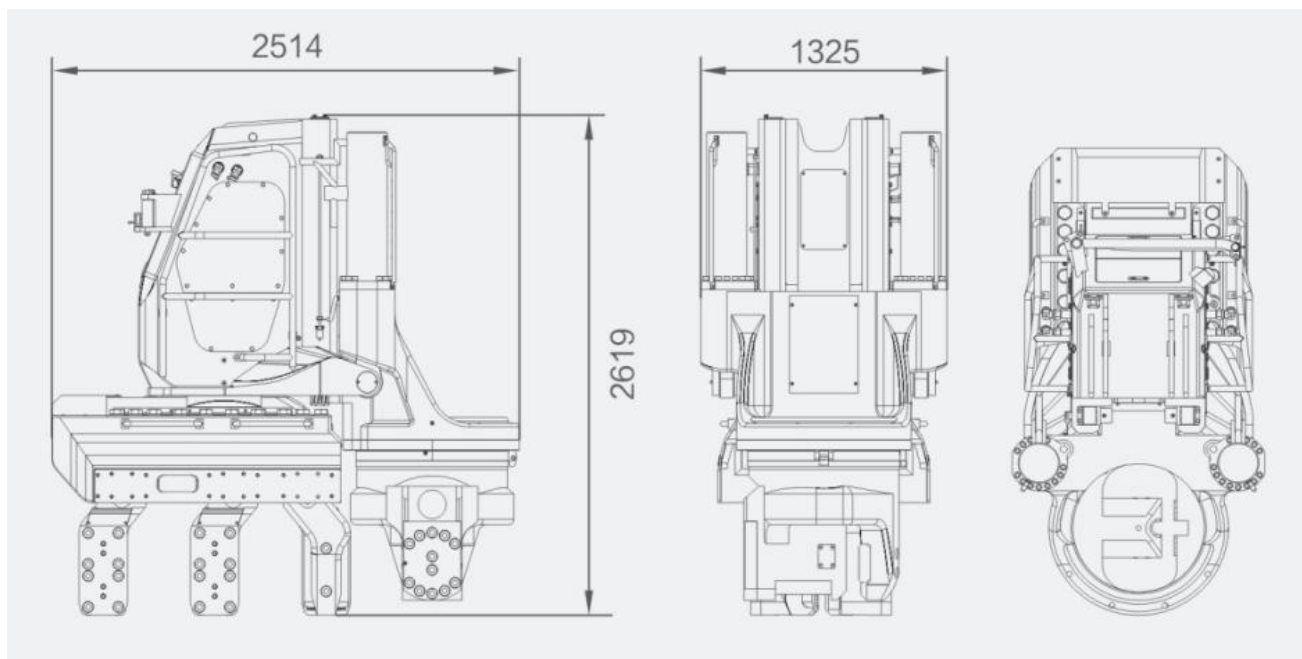

600Y SPECIFICATION

LxWxH (Excluding base)	mm	2514x1325x2619
Weight (Excluding base)	kg	9985
LxWxH of Counterforce base	mm	3587x2280x500
Weight of Counterforce base	kg	3400
Max pile driving force	T	150
Max pulling force	T	160
Applicable pile type	U600 Series	

600Y Base parameter:

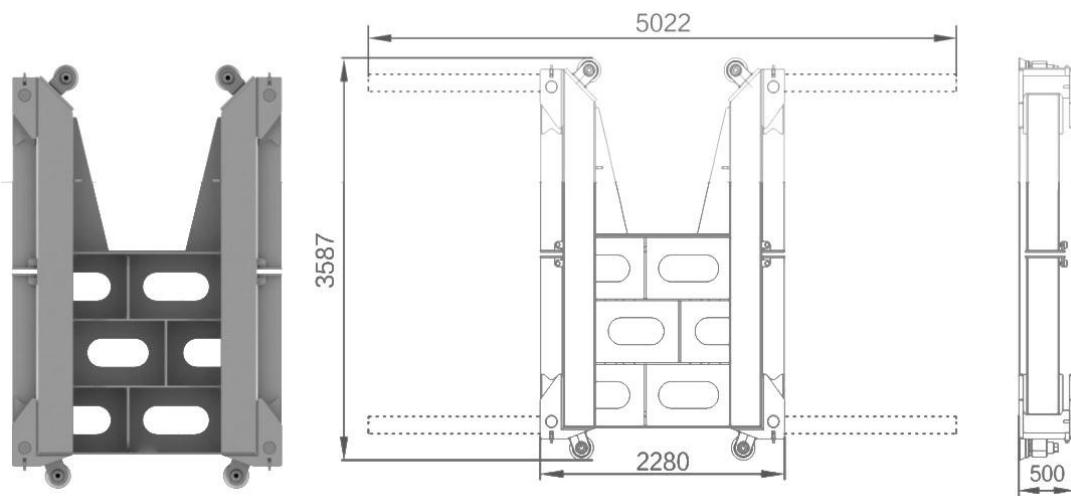

NOTE!

! Preliminary selection. When making the final selection soil and site conditions shall be taken into account.
 ! Specifications are subject to change without notice.